

EANCOM[®] 2002 S4

IFTSTA

International multimodal status report message

Edition 2016 Upd. 2021

| | |
|----------------------------------|----|
| 1. Introduction..... | 2 |
| 2. Message Structure Chart | 4 |
| 3. Branching Diagram..... | 5 |
| 4. Segments Description | 9 |
| 5. Segments Layout..... | 12 |
| 6. Example(s) | 46 |

1. Introduction

Status

MESSAGE TYPE : IFTSTA
REFERENCE DIRECTORY : D.01B
EANCOM® SUBSET VERSION : 004

Definition

A message to report the transport status and/or a change in the transport status (i.e. event) between agreed parties.

Principles

This message allows for the exchange of information regarding the status of the physical movement of consignments or goods at any point (in time or place) within the full transport chain.

A status message may be sent:

- as the result of a request or requests for information regarding a consignment or consignments;
- on a scheduled basis at predetermined times;
- on the occurrence of a selected event or events;
- on the occurrence of an exceptional event as agreed by the partners involved.

This message can relate to a status (or status's) that has (or have) been reached in a transport chain. Additionally, the message may report an exceptional status and the reason for that exceptional status.

In addition to the main principles detailed above, a number of general principles also apply;

- A consignment may contain several goods items.
- A consignment is identified by a consignor's reference number (code CU) in the CNI segment.
- Goods items may or may not be containerised.
- Goods items may be transported in one or more containers, and a single container may contain one or more goods items.
- One goods item may be related to one or more customs tariff codes.
- Goods items related to one customs tariff code may be carried in one or more containers.
- Pre-carriage (advanced haulage) and/or on-carriage (destination haulage) of goods items or equipment within one booking or instruction may take place in different steps, each step specified with its own transport details group.
- Transport devices, which have the ability of powered movement on their own, are specified in the transport details group. Other load or transport devices are specified as equipment.
- Packaging for goods items can be expressed at up to three levels.
- A goods item consists of one or more despatch units that adhere to the same package type and goods description.
- A despatch unit is the unit of cargo that will be handled and to which an SSCC can be affixed.

A number of generic transport terms are used in this specification, to be described as:

CONSIGNEE

the organisation (party) which has the intention to receive the goods.

1. Introduction

CONSIGNOR

the party ordering transport, orders a carrier to collect goods for transportation.

CONSIGNMENT

is a shipment from one or many despatch locations to one or many delivery locations for one consignor and one consignee.

CARRIER

the party contracted by the consignor or forwarder to transport goods.

DESPATCH LOCATION

the physical location from which goods for transport are shipped.

DELIVERY LOCATION

the physical location to which goods for transport are finally delivered.

EQUIPMENT

material resources necessary to facilitate the transport and handling of cargo. Transport equipment does under the given circumstances not have the ability to move by its own propulsion (e.g. sea container, trailer, unit load device, pallet).

FORWARDER

the party contracted by the consignor to arrange to have the goods transported.

GOODS ITEM

a collection of products normally grouped together for transport purposes, e.g. 12 pallets of foodstuffs.

LINE ITEM

a specific product identified and defined for trade purposes, e.g. a case of flour containing 24 packets of 250 grams.

MODE OF TRANSPORT

the method of transport used for the conveyance of goods or persons, e.g. by rail, by road, by sea.

MEANS OF TRANSPORT

the vehicle used for the transport of goods or persons, e.g. aircraft, truck, vessel.

PLACE OF ACCEPTANCE

the place at which the responsibility of the carrier starts.

PLACE OF DELIVERY

the place at which the responsibility of the carrier ends.

TYPE OF MEANS OF TRANSPORT

the type of vehicle used in the transport process, e.g. wide body, tank truck, passenger vessel.

TYPE OF EQUIPMENT

the type of material used, e.g. 40 feet container, four way pallet, mafi trailer.

2. Message Structure Chart

| | | | | |
|-----|---|---|---|-------------------------|
| UNA | 1 | C | 1 | - Service string advice |
| UNB | 2 | M | 1 | - Interchange header |

Transport Status Heading Section

| | | | | |
|-----|---|---|---|------------------------|
| UNH | 3 | M | 1 | - Message header |
| BGM | 4 | M | 1 | - Beginning of message |
| DTM | 5 | C | 9 | - Date/time/period |
| SG1 | | C | 9 | - NAD |
| NAD | 6 | M | 1 | - Name and address |
| SG3 | | C | 9 | - RFF |
| RFF | 7 | M | 1 | - Reference |
| FTX | 8 | C | 9 | - Free text |

Transport Status Detail Section

| | | | | |
|------|----|---|-------|------------------------------------|
| SG4 | | C | 99999 | - CNI-SG5 |
| CNI | 9 | M | 1 | - Consignment information |
| SG5 | * | M | 99 | - STS-RFF-DTM-FTX-SG6-LOC-SG8-SG12 |
| STS | 10 | M | 1 | - Status |
| RFF | 11 | C | 999 | - Reference |
| DTM | 12 | C | 9 | - Date/time/period |
| FTX | 13 | C | 9 | - Free text |
| SG6 | + | C | 9 | - NAD |
| NAD | 14 | M | 1 | - Name and address |
| LOC | 15 | C | 1 | - Place/location identification |
| SG8 | + | C | 99 | - TDT-SG9 |
| TDT | + | M | 1 | - Details of transport |
| SG9 | + | C | 9 | - LOC-DTM |
| LOC | + | M | 1 | - Place/location identification |
| DTM | + | C | 9 | - Date/time/period |
| SG12 | * | C | 99 | - GID-SG13-SG14-SG15 |
| GID | 19 | M | 1 | - Goods item details |
| SG13 | + | C | 99 | - MEA |
| MEA | + | M | 1 | - Measurements |
| SG14 | + | C | 99 | - DIM |
| DIM | + | M | 1 | - Dimensions |
| SG15 | | C | 99 | - PCI-GIN |
| PCI | 22 | M | 1 | - Package identification |
| GIN | 23 | C | 9 | - Goods identity number |

Transport Status Summary Section

| | | | | |
|-----|----|---|---|-----------------------|
| UNT | 24 | M | 1 | - Message trailer |
| UNZ | 25 | M | 1 | - Interchange trailer |

3. Branching Diagram

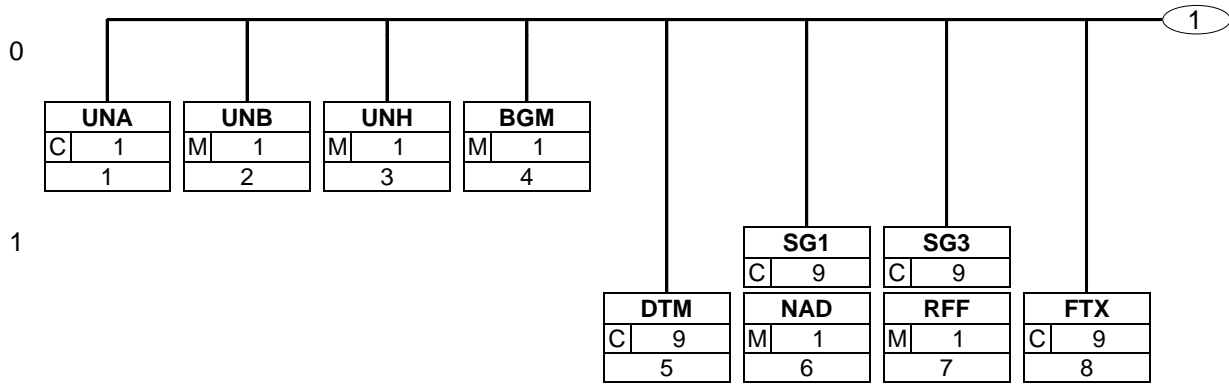

3. Branching Diagram

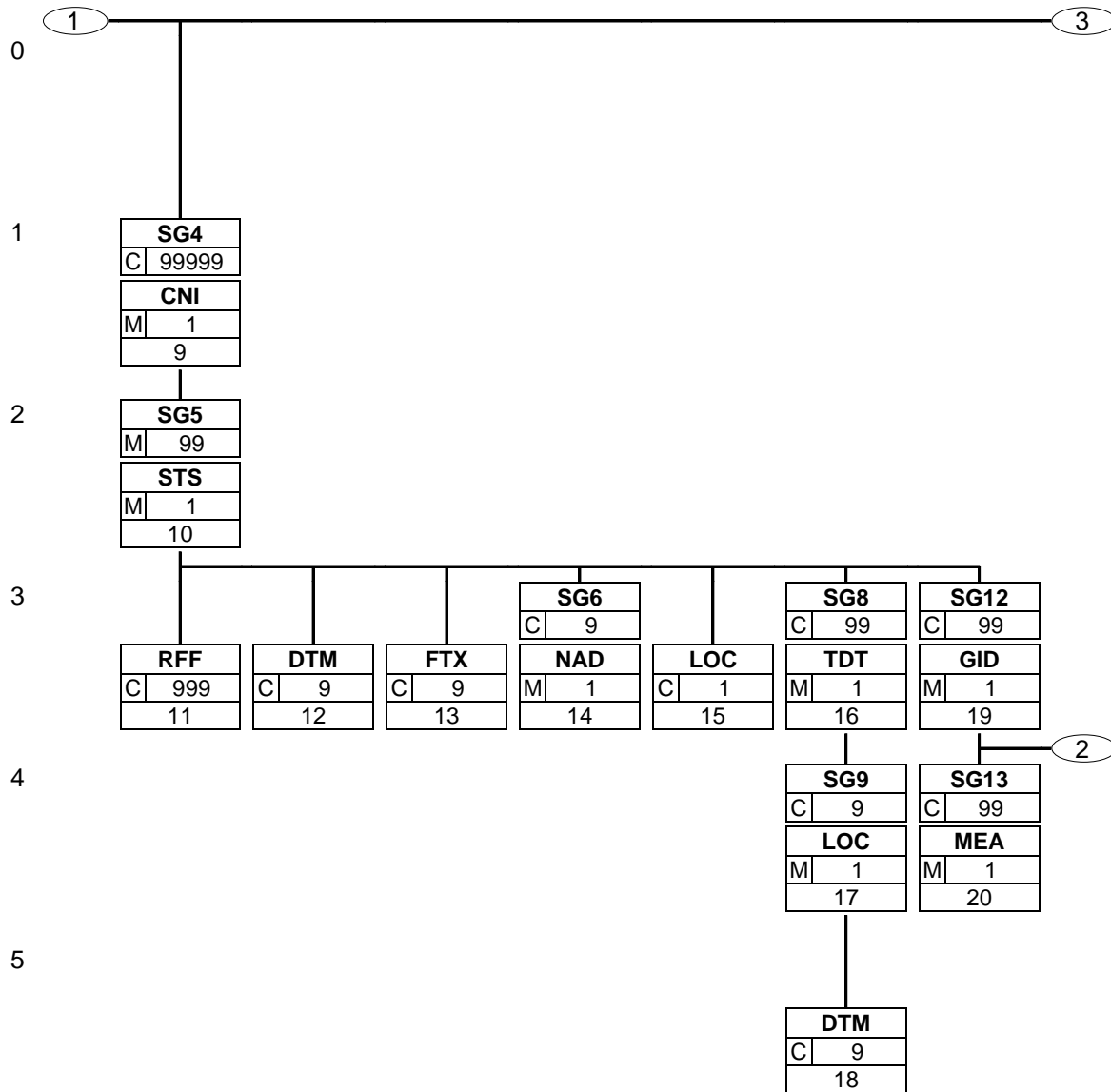

3. Branching Diagram

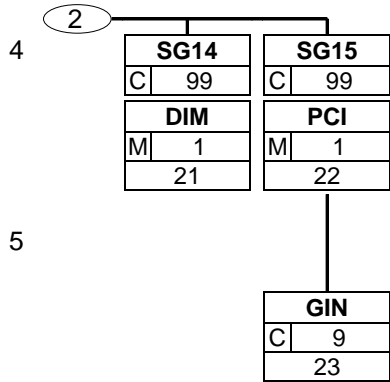

3. Branching Diagram

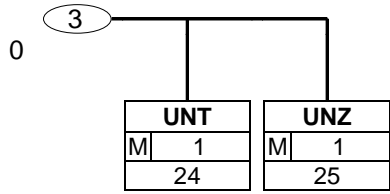

4. Segments Description

- UNA - C 1 - Service string advice
This segment is used to inform the receiver of the interchange that a set of service string characters which are different to the default characters are being used.
- UNB - M 1 - Interchange header
This segment is used to envelope the interchange, as well as to identify both, the party to whom the interchange is sent and the party who has sent the interchange. The principle of the UNB segment is the same as a physical envelope which covers one or more letters or documents, and which details, both the address where delivery is to take place and the address from where the envelope has come.

Transport Status Heading Section

- UNH - M 1 - Message header
This segment is used to head, identify and specify a message.
- BGM - M 1 - Beginning of message
This segment is used to indicate the type and function of a message and to transmit the identifying number.
- DTM - C 9 - Date/time/period
This segment is used to specify the date of the transport status message.
- SG1** - C 9 - **NAD**
A group of segments to identify the trading partners involved in the transport status message.
- NAD - M 1 - Name and address
This segment is used to identify the trading partners involved in the Transport Status message. Identification of the Carrier (CA) and Consignor (CZ) is mandatory in the transport status message, either in this segment or in the NAD segment of group 6. If required, a consignee or freight forwarder may also be identified using NAD at this level in the message.
- SG3** - C 9 - **RFF**
To specify references such as shipment reference number.
- RFF - M 1 - Reference
This segment is used to specify references relating to a previously sent transport instruction for which a status is being requested or provided.
- FTX - C 9 - Free text
This segment is used to provide any free text information related to the entire message.

Transport Status Detail Section

- SG4** - C 99999 - **CNI-SG5**
A group of segments to identify a consignment and status details relating to it.
- CNI - M 1 - Consignment information
This segment is used to identify a consignment for which status information is being provided. In the IFTMnn messages the consignor's shipment reference number is provided in data element 1153 of the RFF segment at the message level using the code value 'CU'.
- SG5** - M 99 - **STS-RFF-DTM-FTX-SG6-LOC-SG8-SG12**
A group of segments indicating the status and/or identifying an event and specifying relevant details.
- STS - M 1 - Status
This segment is used to request or provide status information regarding the currently referenced consignment.

4. Segments Description

| | |
|--------------------|--|
| RFF - C 999 | - Reference This segment is used to identify any reference associated with the status information in the STS segment. |
| DTM - C 9 | - Date/time/period This segment is used to specify any dates associated with the consignment for which status information is being requested or provided. |
| FTX - C 9 | - Free text This segment is used to provide any free text information related to the status detailed in the STS segment. |
| SG6 - C 9 | - NAD A group of segments to identify a party associated with the event. |
| NAD - M 1 | - Name and address This segment is used to specify parties related to the status provided in the STS segment. |
| LOC - C 1 | - Place/location identification This segment is used to indicate a location relevant to the status provided in the STS segment. |
| SG8 - C 99 | - TDT-SG9 A group of segments indicating conveyance details related to the status or event. |
| TDT - M 1 | - Details of transport This segment is used to specify transport details for the current consignment. |
| SG9 - C 9 | - LOC-DTM A group of segments indicating locations and dates related to the means of transport. |
| LOC - M 1 | - Place/location identification This segment is used to identify any locations related to the transport details specified in the previous TDT segment. |
| DTM - C 9 | - Date/time/period This segment is used to specify any dates relating to the transport specified in the previous TDT segment. |
| SG12 - C 99 | - GID-SG13-SG14-SG15 A group of segments describing the goods item related to the status or event. |
| GID - M 1 | - Goods item details This segment is used to identify goods items for which status information is being provided in the STS segment. |
| SG13 - C 99 | - MEA A group of segments specifying measurements. |
| MEA - M 1 | - Measurements This segment is used to specify the total net and gross weight of the goods item identified in GID. |
| SG14 - C 99 | - DIM A group of segments specifying dimensions of a goods item. |
| DIM - M 1 | - Dimensions This segment is used to indicate the dimensions of the goods item identified in the GID segment. |
| SG15 - C 99 | - PCI-GIN A group of segments specifying marks and numbers related to the transport line items. |

4. Segments Description

- PCI - M 1 - Package identification
This segment is used to specify markings and labels for the line item identified in the GID segment.
- GIN - C 9 - Goods identity number
This segment is used to provide the Serial Shipping Container Code marked on the packaging of the current goods item.

Transport Status Summary Section

- UNT - M 1 - Message trailer
This UNT segment is a mandatory UN/EDIFACT segment. It must always be the last segment in the message.
- UNZ - M 1 - Interchange trailer
This segment is used to provide the trailer of an interchange.

5. Segments Layout

This section describes each segment used in the EANCOM® Transport status message. The original EDIFACT segment layout is listed. The appropriate comments relevant to the EANCOM® subset are indicated.

Notes:

1. The segments are presented in the sequence in which they appear in the message. The segment or segment group tag is followed by the (M)andatory / (C)onditional indicator, the maximum number of occurrences and the segment description.
2. Reading from left to right, in column one, the data element tags and descriptions are shown, followed by in the second column the EDIFACT status (M or C), the field format, and the picture of the data elements. These first pieces of information constitute the original EDIFACT segment layout.

Following the EDIFACT information, EANCOM® specific information is provided in the third, fourth, and fifth columns. In the third column a status indicator for the use of (C)onditional EDIFACT data elements (see 2.1 through 2.3 below), in the fourth column the restricted indicator (see point 3 on the following page), and in the fifth column notes and code values used for specific data elements in the message.

- 2.1 (M)andatory data elements in EDIFACT segments retain their status in EANCOM®.
- 2.2 Additionally, there are five types of status for data elements with a (C)onditional EDIFACT status, whether for simple, component or composite data elements. These are listed below and can be identified when relevant by the following abbreviations:

| | | |
|-------------|----------|--|
| - REQUIRED | R | Indicates that the entity is required and must be sent. |
| - ADVISED | A | Indicates that the entity is advised or recommended. |
| - DEPENDENT | D | Indicates that the entity must be sent in certain conditions, as defined by the relevant explanatory note. |
| - OPTIONAL | O | Indicates that the entity is optional and may be sent at the discretion of the user. |
| - NOT USED | N | Indicates that the entity is not used and should be omitted. |

- 2.3 If a composite is flagged as **N, NOT USED**, all data elements within that composite will have blank status indicators assigned to them.
3. Status indicators detailed in the fourth column which directly relate to the code values detailed in the fifth **column** may have two values:

| | | |
|--------------|---|---|
| - RESTRICTED | * | A data element marked with an asterisk (*) in the fourth column indicates that the listed codes in column five are the only codes available for use with this data element, in this segment, in this message. |
| - OPEN | | All data elements where coded representation of data is possible and a restricted set of code values is not indicated are open (no asterisk in fourth column). The available codes are listed in the EANCOM® Data Elements and Code Sets Directory. Code values may be given as examples or there may be a note on the format or type of code to be used. |

4. Different colours are used for the code values in the segment details: restricted codes are in red and open codes in blue.

5. Segments Layout

Segment number: 1

| UNA - C 1 - Service string advice | | | | |
|--|----------------------------------|-------|-----|--|
| Function: | | | | |
| The service string advice shall begin with the upper case characters UNA immediately followed by six characters in the order shown below. The space character shall not be used in positions 010, 020, 040, 050 or 060. The same character shall not be used in more than one position of the UNA. | | | | |
| | EDIFACT | GS1 | * | Description |
| UNA1 | Component data element separator | M an1 | M * | Used as a separator between component data elements contained within a composite data element (default value: ":") |
| UNA2 | Data element separator | M an1 | M * | Used to separate two simple or composite data elements (default value: "+") |
| UNA3 | Decimal mark | M an1 | M * | Used to indicate the character used for decimal notation (default value:".") |
| UNA4 | Release character | M an1 | M * | Used to restore any service character to its original specification (value: "?"). |
| UNA5 | Repetition separator | M an1 | M * | Used to indicate the character used for repetition separation (value: " * "). |
| UNA6 | Segment terminator | M an1 | M * | Used to indicate the end of segment data (default value: " ' ") |
| Segment Notes: | | | | |
| This segment is used to inform the receiver of the interchange that a set of service string characters which are different to the default characters are being used. | | | | |
| When using the default set of service characters, the UNA segment need not be sent. If it is sent, it must immediately precede the UNB segment and contain the four service string characters (positions UNA1, UNA2, UNA4 and UNA6) selected by the interchange sender. | | | | |
| Regardless of whether or not all of the service string characters are being changed every data element within this segment must be filled, (i.e., if some default values are being used with user defined ones, both the default and user defined values must be specified). | | | | |
| When expressing the service string characters in the UNA segment, it is not necessary to include any element separators. | | | | |
| The use of the UNA segment is required when using a character set other than level A. | | | | |
| UNA:+.?*' | | | | |

5. Segments Layout

Segment number: 2

| UNB - M 1 - Interchange header | | | | |
|---|---|---------|-----|--|
| Function: To identify an interchange. | | | | |
| Notes: 1. S001/0002, shall be '4' to indicate this version of the syntax. 2. The combination of the values carried in data elements S002, S003 and 0020 shall be used to identify uniquely the interchange, for the purpose of acknowledgement. | | | | |
| | EDIFACT | GS1 | * | Description |
| S001 | SYNTAX IDENTIFIER | M | M | See Part I chapter 5.2.7 and segment notes. |
| 0001 | Syntax identifier | Ma4 | M * | UNOA = UN/ECE level A UNOB = UN/ECE level B UNOC = UN/ECE level C UNOD = UN/ECE level D UNOE = UN/ECE level E UNOF = UN/ECE level F UNOG = UN/ECE level G UNOH = UN/ECE level H UNOI = UN/ECE level I UNOJ = UN/ECE level J UNOK = UN/ECE level K UNOW = UN/ECE level W UNOX = UN/ECE level X UNOY = UN/ECE level Y |
| 0002 | Syntax version number | Man1 | M * | 4 = Version 4 |
| 0080 | Service code list directory version number | Can..6 | N | |
| 0133 | Character encoding, coded | Can..3 | N | |
| S002 | INTERCHANGE SENDER | M | M | |
| 0004 | Interchange sender identification | Man..35 | M | GLN (n13) |
| 0007 | Identification code qualifier | Can..4 | R * | 14 = GS1 |
| 0008 | Interchange sender internal identification | Can..35 | O | |
| 0042 | Interchange sender internal sub-identification | Can..35 | N | |
| S003 | INTERCHANGE RECIPIENT | M | M | |
| 0010 | Interchange recipient identification | Man..35 | M | GLN (n13) |
| 0007 | Identification code qualifier | Can..4 | R * | 14 = GS1 |
| 0014 | Interchange recipient internal identification | Can..35 | O | |
| 0046 | Interchange recipient internal sub-identification | Can..35 | N | |
| S004 | DATE AND TIME OF PREPARATION | M | M | |
| 0017 | Date | Mn8 | M | CCYYMMDD |
| 0019 | Time | Mn4 | M | HHMM |
| 0020 | Interchange control reference | Man..14 | M | Unique reference identifying the interchange. Created |

5. Segments Layout

Segment number: 2

| | | EDIFACT | GS1 | * | Description |
|------|---|----------|-----|----------|--|
| | | | | | by the interchange sender. |
| S005 | RECIPIENT REFERENCE/ PASSWORD DETAILS | C | | O | |
| 0022 | Recipient reference/password | M an..14 | | M | |
| 0025 | Recipient reference/password qualifier | C an2 | | O | |
| 0026 | Application reference | C an..14 | | O | Message identification if the interchange contains only one type of message. |
| 0029 | Processing priority code | C a1 | | O | A = Highest priority |
| 0031 | Acknowledgement request | C n1 | | O | 1 = Requested |
| 0032 | Interchange agreement identifier | C an..35 | | O | * EANCOM..... |
| 0035 | Test indicator | C n1 | | O | 1 = Interchange is a test |

Segment Notes:

This segment is used to envelope the interchange, as well as to identify both, the party to whom the interchange is sent and the party who has sent the interchange. The principle of the UNB segment is the same as a physical envelope which covers one or more letters or documents, and which details, both the address where delivery is to take place and the address from where the envelope has come.

S001: The character encoding specified in basic code table of ISO/IEC 646 (7-bit coded character set for information interchange) shall be used for the interchange service string advice (if used) and up to and including the composite data element S001 'Syntax identifier' in the interchange header. The character repertoire used for the characters in an interchange shall be identified from the code value of data element 0001 in S001 'Syntax identifier' in the interchange header. The character repertoire identified does not apply to objects and/or encrypted data.

The default encoding technique for a particular repertoire shall be the encoding technique defined by its associated character set specification.

DE 0001: The recommended (default) character set for use in EANCOM® for international exchanges is character set A (UNOA). Should users wish to use character sets other than A, an agreement on which set to use should be reached on a bilateral basis before communications begin.

DE 0004, 0008, 0010 and 0014: Within EANCOM® the use of the Global Location Number (GLN) is recommended for the identification of the interchange sender and recipient.

DE 0008: Identification (e.g. a division) specified by the sender of the interchange, to be included if agreed, by the recipient in response interchanges, to facilitate internal routing.

DE 0014: The address for routing, provided beforehand by the interchange recipient, is used by the interchange sender to inform the recipient of the internal address, within the latter's systems, to which the interchange should be routed. It is recommended that the GLN be used for this purpose.

DE 0007: Identification (e.g. a division) specified by the recipient of the interchange, to be included if agreed, by the sender in response interchanges, to facilitate internal routing.

DE S004: The date and time specified in this composite should be the date and time at which the interchange sender prepared the interchange. This date and time may not necessarily be the same as the date and time of contained messages.

DE 0020: The interchange control reference number is generated by the interchange sender and is used to identify uniquely each interchange. Should the interchange sender wish to re-use interchange control reference numbers, it is recommended that each number be preserved for at least a period of three months before being re-used. In order to guarantee uniqueness, the interchange control reference number should always be linked to the interchange sender's identification (DE 0004).

DE S005: The use of passwords must first be agreed bilaterally by the parties exchanging the interchange.

DE 0026: This data element is used to identify the application, on the interchange recipient's system, to which the interchange is directed. This data element may only be used if the interchange contains only one type of message, (e.g. only invoices). The reference used in this data element is assigned by the interchange sender.

DE 0031: This data element is used to indicate whether an acknowledgement to the interchange is required. The EANCOM® APERAK or CONTRL message should be used to provide acknowledgement of interchange receipt.

In addition, the EANCOM® CONTRL message may be used to indicate when an interchange has been rejected

5. Segments Layout

Segment number: 2

due to syntax errors.

DE 0032: This data element is used to identify any underlying agreements which control the exchange of data. Within EANCOM®, the identity of such agreements must start with the letters 'EANCOM', the remaining characters within the data element being filled according to bilateral agreements.

UNB+UNOC:4+5412345678908:14+8798765432106:14+20020102:1000+12345555+++++EANCOMREF 52'

5. Segments Layout

Segment number: 3

| UNH - M 1 - Message header | | | | | |
|---|---|----------|-----|---|---|
| Function: To head, identify and specify a message. | | | | | |
| Notes: 1. Data element S009/0057 is retained for upward compatibility. The use of S016 and/or S017 is encouraged in preference. 2. The combination of the values carried in data elements 0062 and S009 shall be used to identify uniquely the message within its group (if used) or if not used, within its interchange, for the purpose of acknowledgement. | | | | | |
| | | EDIFACT | GS1 | * | Description |
| 0062 | Message reference number | M an..14 | M | | Senders unique message reference. Sequence number of the messages in the interchange. DE 0062 in the UNT will be identical. Sender generated. |
| S009 | MESSAGE IDENTIFIER | M | M | | |
| 0065 | Message type | M an..6 | M | * | IFTSTA = International multimodal status report message |
| 0052 | Message version number | M an..3 | M | * | D = Draft version/UN/EDIFACT Directory |
| 0054 | Message release number | M an..3 | M | * | 01B = Release 2001 - B |
| 0051 | Controlling agency, coded | M an..3 | M | * | UN = UN/CEFACT |
| 0057 | Association assigned code | C an..6 | R | * | EAN004 = GS1 version control number (GS1 Permanent Code) Indicates that the message is the EANCOM version 004 of the UNSM Transport Status. |
| 0110 | Code list directory version number | C an..6 | O | | This data element can be used to identify the codelist agreed by the interchange partners, e.g. EAN001 = EANCOM 2002 S4 codelist released on 01.12.2002 by GS1. |
| 0113 | Message type sub-function identification | C an..6 | N | | |
| 0068 | Common access reference | C an..35 | N | | |
| S010 | STATUS OF THE TRANSFER | C | N | | |
| 0070 | Sequence of transfers | M n..2 | | | |
| 0073 | First and last transfer | C a1 | | | |
| S016 | MESSAGE SUBSET IDENTIFICATION | C | N | | |
| 0115 | Message subset identification | M an..14 | | | |
| 0116 | Message subset version number | C an..3 | | | |
| 0118 | Message subset release number | C an..3 | | | |
| 0051 | Controlling agency, coded | C an..3 | | | |
| S017 | MESSAGE IMPLEMENTATION GUIDELINE IDENTIFICATION | C | N | | |
| 0121 | Message implementation guideline identification | M an..14 | | | |
| 0122 | Message implementation guideline version number | C an..3 | | | |

5. Segments Layout

Segment number: 3

| | EDIFACT | GS1 | * | Description |
|------|---|----------|----------|-------------|
| 0124 | Message implementation guideline release number | C an..3 | | |
| 0051 | Controlling agency, coded | C an..3 | | |
| S018 | SCENARIO IDENTIFICATION | C | N | |
| 0127 | Scenario identification | M an..14 | | |
| 0128 | Scenario version number | C an..3 | | |
| 0130 | Scenario release number | C an..3 | | |
| 0051 | Controlling agency, coded | C an..3 | | |

Segment Notes:

This segment is used to head, identify and specify a message.

DE's 0065, 0052, 0054, and 0051: Indicate that the message is a UNSM Transport Status message based on the D.01B directory under the control of the United Nations.

Example:

UNH+ME000001+IFTSTA:D:01B:UN:EAN004'

5. Segments Layout

Segment number: 4

| BGM - M 1 - Beginning of message | | | | | |
|---|-----------------------------------|----------|-----|---|--|
| Function: To indicate the type and function of a message and to transmit the identifying number. | | | | | |
| | | EDIFACT | GS1 | * | Description |
| C002 | DOCUMENT/MESSAGE NAME | C | R | | |
| 1001 | Document name code | C an..3 | R | * | 44 = Transport status report 77 = Consignment status report |
| 1131 | Code list identification code | C an..17 | N | | |
| 3055 | Code list responsible agency code | C an..3 | N | | |
| 1000 | Document name | C an..35 | O | | |
| C106 | DOCUMENT/MESSAGE IDENTIFICATION | C | R | | |
| 1004 | Document identifier | C an..35 | R | | Transport status number assigned by the document sender. For global unique identification of documents Global Document Type Identifier (GDTI) is available. |
| 1056 | Version identifier | C an..9 | N | | |
| 1060 | Revision identifier | C an..6 | N | | |
| 1225 | Message function code | C an..3 | R | * | 9 = Original 9 = Original - An original transmission of a transport status message. |
| 4343 | Response type code | C an..3 | N | | |
| Segment Notes: This segment is used to indicate the type and function of a message and to transmit the identifying number. All references other than the document number DE 1004 are to be put in the RFF segment. Example: BGM+44+569952+9' | | | | | |

5. Segments Layout

Segment number: 5

| DTM - C 9 - Date/time/period | | EDIFACT | GS1 | * | Description |
|---|--|----------|-----|---|--------------------------------------|
| Function: To specify date, and/or time, or period. | | | | | |
| C507 | DATE/TIME/PERIOD | M | M | | |
| 2005 | Date or time or period function code qualifier | M an..3 | M | * | 137 = Document/message date/time |
| 2380 | Date or time or period value | C an..35 | R | | |
| 2379 | Date or time or period format code | C an..3 | R | | 102 = CCYYMMDD 203 = CCYYMMDDHHMM |
| Segment Notes: This segment is used to specify the date of the transport status message. DE 2005: Identification of the 'Document/message date/time' (code value 137) is mandatory in an EANCOM message. Example: DTM+137:20020801:102' | | | | | |

5. Segments Layout

Segment number: 6

| SG1 | - C | 9 - NAD | | | |
|--|---|----------------------|----------|---|--|
| NAD | - M | 1 - Name and address | | | |
| Function: | | | | | |
| To specify the name/address and their related function, either by C082 only and/or unstructured by C058 or structured by C080 thru 3207. | | | | | |
| | | EDIFACT | GS1 | * | Description |
| 3035 | Party function code qualifier | M an..3 | M | | CA = Carrier CN = Consignee CZ = Consignor FW = Freight forwarder |
| C082 | PARTY IDENTIFICATION DETAILS | C | A | | |
| 3039 | Party identifier | M an..35 | M | | GLN - Format n13 For the identification of parties it is recommended to use GLN - Format n13. |
| 1131 | Code list identification code | C an..17 | N | | |
| 3055 | Code list responsible agency code | C an..3 | R | * | 9 = GS1 |
| C058 | NAME AND ADDRESS | C | O | | This composite may only be used to fulfill the requirements of directive 2003/58/EC, article 4. |
| 3124 | Name and address description | M an..35 | M | | |
| 3124 | Name and address description | C an..35 | O | | |
| 3124 | Name and address description | C an..35 | O | | |
| 3124 | Name and address description | C an..35 | O | | |
| 3124 | Name and address description | C an..35 | O | | |
| C080 | PARTY NAME | C | D | | |
| 3036 | Party name | M an..35 | M | | Party Name, clear text |
| 3036 | Party name | C an..35 | O | | |
| 3036 | Party name | C an..35 | O | | |
| 3036 | Party name | C an..35 | O | | |
| 3036 | Party name | C an..35 | O | | |
| 3045 | Party name format code | C an..3 | O | | |
| C059 | STREET | C | D | | |
| 3042 | Street and number or post office box identifier | M an..35 | M | | Building Name/Number and Street |
| 3042 | Street and number or post office box identifier | C an..35 | O | | Name and/or P.O. Box |
| 3042 | Street and number or post office box identifier | C an..35 | O | | |
| 3042 | Street and number or post office box identifier | C an..35 | O | | |
| 3164 | City name | C an..35 | D | | City/Town, clear text |
| C819 | COUNTRY SUB-ENTITY DETAILS | C | D | | |
| 3229 | Country sub-entity name code | C an..9 | O | | |

5. Segments Layout

Segment number: 6

| | EDIFACT | GS1 | * | Description |
|--|----------|-----|---|---------------------------|
| 1131 Code list identification code | C an..17 | O | | |
| 3055 Code list responsible agency code | C an..3 | O | | |
| 3228 Country sub-entity name | C an..70 | O | | County/State, clear text. |
| 3251 Postal identification code | C an..17 | D | | Postal Code |
| 3207 Country name code | C an..3 | D | | ISO 3166 two alpha code |

Segment Notes:

This segment is used to identify the trading partners involved in the Transport Status message. Identification of the Carrier (CA) and Consignor (CZ) is mandatory in the transport status message, either in this segment or in the NAD segment of group 6. If required, a consignee or freight forwarder may also be identified using NAD at this level in the message.

Example:

NAD+CN+5411234512309::9'
 NAD+CZ+5412345123453::9'

Dependency Notes:

The following composites and data elements are only used when a coded name and address can not be used.

The affected composites and data elements are as follows:

C080 - C059 - 3164 - C819 - 3251 - 3207

5. Segments Layout

Segment number: 7

| SG3 | - C | 9 - RFF | | | |
|---|------------------------------|---------------|-----|---|---|
| RFF | - M | 1 - Reference | | | |
| Function: | | | | | |
| To specify a reference. | | | | | |
| | | EDIFACT | GS1 | * | Description |
| C506 | REFERENCE | M | M | | |
| 1153 | Reference code qualifier | M an..3 | M | | AAS = Transport document number TIN = Transport instruction number |
| 1154 | Reference identifier | C an..70 | R | | |
| 1156 | Document line identifier | C an..6 | N | | |
| 4000 | Reference version identifier | C an..35 | N | | |
| 1060 | Revision identifier | C an..6 | N | | |
| Segment Notes: | | | | | |
| This segment is used to specify references relating to a previously sent transport instruction for which a status is being requested or provided. | | | | | |
| Example: | | | | | |
| RFF+TRI:76214' | | | | | |

5. Segments Layout

Segment number: 8

| FTX - C 9 - Free text | | | | |
|--|-----------------------------------|-----------|----------|---|
| Function: To provide free form or coded text information. | | | | |
| | | EDIFACT | GS1 * | Description |
| 4451 | Text subject code qualifier | M an..3 | M | AAI = General information BAP = External link |
| 4453 | Free text function code | C an..3 | O | 1 = Text for subsequent use |
| C107 | TEXT REFERENCE | C | D | This composite is only used when trading partners have agreed to use mutually defined code values. |
| 4441 | Free text value code | M an..17 | M | 78E = Proof Of Delivery (GS1 Permanent Code) |
| 1131 | Code list identification code | C an..17 | O | |
| 3055 | Code list responsible agency code | C an..3 | D | 9 = GS1 91 = Assigned by supplier or supplier's agent 92 = Assigned by buyer or buyer's agent |
| C108 | TEXT LITERAL | C | D | This composite is only used if coded text can not be used. |
| 4440 | Free text value | M an..512 | M | |
| 4440 | Free text value | C an..512 | O | |
| 4440 | Free text value | C an..512 | O | |
| 4440 | Free text value | C an..512 | O | |
| 4440 | Free text value | C an..512 | O | |
| 3453 | Language name code | C an..3 | D | ISO 639 two alpha code This data element is only used when non coded free text has been provided in data element C108. |
| 4447 | Free text format code | C an..3 | N | |
| <p>Segment Notes:</p> <p>This segment is used to provide any free text information related to the entire message. Use of this segment in free form is not recommended since it may inhibit automatic processing of the Transport Status. Coded references to standard texts is an available functionality which enables automatic processing and reduces transmission overheads. Standard texts should be mutually defined between trading partners and can be used to cover legal or other requirements.</p> <p>Example: FTX+AAI+1+483::91' (Supplier assigned Code value 483 = Please confirm status of all outstanding deliveries.)</p> | | | | |

5. Segments Layout

Segment number: 9

| SG4 | - C | 99999 - CNI-SG5 | | | |
|---|--------------------------------------|-----------------------------|-----|---|--|
| CNI | - M | 1 - Consignment information | | | |
| Function: To identify one consignment. | | | | | |
| | | EDIFACT | GS1 | * | Description |
| 1490 | Consolidation item number | C n..4 | R | | Serial number differentiating each separate consignment included in the status report. |
| C503 | DOCUMENT/MESSAGE DETAILS | C | R | | |
| 1004 | Document identifier | C an..35 | R | | Consignor's shipment reference number |
| 1373 | Document status code | C an..3 | N | | |
| 1366 | Document source description | C an..70 | N | | |
| 3453 | Language name code | C an..3 | N | | |
| 1056 | Version identifier | C an..9 | N | | |
| 1060 | Revision identifier | C an..6 | N | | |
| 1312 | Consignment load sequence identifier | C n..4 | O | | This data element is used to indicate the sequence in which a consignment is to be, or has been, loaded. |
| <p>Segment Notes:</p> <p>This segment is used to identify a consignment for which status information is being provided. In the IFTMnn messages the consignor's shipment reference number is provided in data element 1153 of the RFF segment at the message level using the code value 'CU'.</p> <p>Example: CNI+12+AVV23441'</p> | | | | | |

5. Segments Layout

Segment number: 10

| SG4 | - C | 99999 - CNI-SG5 | | |
|---|-----------------------------------|---------------------------------------|-------------|---|
| SG5 | - M | 99 - STS-RFF-DTM-FTX-SG6-LOC-SG8-SG12 | | |
| STS | - M | 1 - Status | | |
| Function: | | | | |
| To specify the status of an object or service, including its category and the reason(s) for the status. | | | | |
| | EDIFACT | GS1 * | Description | |
| C601 | STATUS CATEGORY | C | O | |
| 9015 | Status category code | M an..3 | M | 1 = Transport |
| 1131 | Code list identification code | C an..17 | O | |
| 3055 | Code list responsible agency code | C an..3 | D | |
| C555 | STATUS | C | O | |
| 4405 | Status description code | M an..3 | M | 13 = Collection/pick-up, completed 21 = Delivery, completed 31 = En route 49 = Lost 1E = Arrived (GS1 Temporary Code) 6E = Booked (GS1 Temporary Code) 72B = Receipt of goods fully acknowledged (GS1 Temporary Code) 76E = Not collected (GS1 Temporary Code) |
| 1131 | Code list identification code | C an..17 | O | |
| 3055 | Code list responsible agency code | C an..3 | D | 9 = GS1 |
| 4404 | Status description | C an..35 | N | |
| C556 | STATUS REASON | C | O | |
| 9013 | Status reason description code | M an..3 | M | 13 = Customs refusal 16 = Destination incorrect 38 = New delivery arrangements 46 = Payment not received 54 = Special service required |
| 1131 | Code list identification code | C an..17 | O | |
| 3055 | Code list responsible agency code | C an..3 | D | 9 = GS1 |
| 9012 | Status reason description | C an..256 | N | |
| C556 | STATUS REASON | C | N | |
| 9013 | Status reason description code | M an..3 | | |
| 1131 | Code list identification code | C an..17 | | |
| 3055 | Code list responsible agency code | C an..3 | | |
| 9012 | Status reason description | C an..256 | | |
| C556 | STATUS REASON | C | N | |
| 9013 | Status reason description code | M an..3 | | |
| 1131 | Code list identification code | C an..17 | | |
| 3055 | Code list responsible agency code | C an..3 | | |

5. Segments Layout

Segment number: 10

| | EDIFACT | GS1 | * | Description |
|--|-----------|----------|---|-------------|
| code | | | | |
| 9012 Status reason description | C an..256 | | | |
| C556 STATUS REASON | C | N | | |
| 9013 Status reason description code | M an..3 | | | |
| 1131 Code list identification code | C an..17 | | | |
| 3055 Code list responsible agency code | C an..3 | | | |
| 9012 Status reason description | C an..256 | | | |
| C556 STATUS REASON | C | N | | |
| 9013 Status reason description code | M an..3 | | | |
| 1131 Code list identification code | C an..17 | | | |
| 3055 Code list responsible agency code | C an..3 | | | |
| 9012 Status reason description | C an..256 | | | |

Segment Notes:

This segment is used to request or provide status information regarding the currently referenced consignment.

Example:

STS+1+76E::9+46'

The consignment has not been collected because payment for the transport has not yet been received.

STS+1+21'

The consignment has been delivered.

Dependency Notes:

DE 3055: This data element is only used when GS1 code values are being used in data element 9015, 4405 or 9013.

5. Segments Layout

Segment number: 11

| SG4 | - C | 99999 - CNI-SG5 | | | |
|--|------------------------------|---------------------------------------|----------|---|---|
| SG5 | - M | 99 - STS-RFF-DTM-FTX-SG6-LOC-SG8-SG12 | | | |
| RFF | - C | 999 - Reference | | | |
| Function: To specify a reference. | | | | | |
| | | EDIFACT | GS1 | * | Description |
| C506 | REFERENCE | M | M | | |
| 1153 | Reference code qualifier | M an..3 | M | | AAS = Transport document number AAU = Despatch note number ALO = Receiving advice number BM = Bill of lading number CT = Contract number CU = Consignor's reference number DQ = Delivery note number FF = Freight forwarder's reference number |
| 1154 | Reference identifier | C an..70 | R | | |
| 1156 | Document line identifier | C an..6 | O | | |
| 4000 | Reference version identifier | C an..35 | N | | |
| 1060 | Revision identifier | C an..6 | N | | |
| Segment Notes: This segment is used to identify any reference associated with the status information in the STS segment. Example: RFF+SRN:6532' | | | | | |

5. Segments Layout

Segment number: 12

| | | |
|------------|-----|---------------------------------------|
| SG4 | - C | 99999 - CNI-SG5 |
| SG5 | - M | 99 - STS-RFF-DTM-FTX-SG6-LOC-SG8-SG12 |
| DTM | - C | 9 - Date/time/period |

Function:

To specify date, and/or time, or period.

| | | EDIFACT | GS1 | * | Description |
|------|--|----------|-----|---|--|
| C507 | DATE/TIME/PERIOD | M | M | | |
| 2005 | Date or time or period function code qualifier | M an..3 | M | | 7 = Effective date/time 35 = Delivery date/time, actual 171 = Reference date/time 200 = Pick-up/collection date/time of cargo 334 = Status change date/time 800 = Next status report date |
| 2380 | Date or time or period value | C an..35 | R | | |
| 2379 | Date or time or period format code | C an..3 | R | | 102 = CCYYMMDD 203 = CCYYMMDDHHMM |

Segment Notes:

This segment is used to specify any dates associated with the consignment for which status information is being requested or provided.

Example:

DTM+171:20020615:102'

5. Segments Layout

Segment number: 13

| SG4 | - C | 99999 - CNI-SG5 | | |
|--|-----------------------------------|---------------------------------------|----------|--|
| SG5 | - M | 99 - STS-RFF-DTM-FTX-SG6-LOC-SG8-SG12 | | |
| FTX | - C | 9 - Free text | | |
| Function: To provide free form or coded text information. | | | | |
| | EDIFACT | GS1 | * | Description |
| 4451 | Text subject code qualifier | M an..3 | M | AAI = General information ACD = Reason BLR = Transport document remarks DEL = Delivery information HAN = Handling instructions TRA = Transportation information |
| 4453 | Free text function code | C an..3 | O | 1 = Text for subsequent use |
| C107 | TEXT REFERENCE | C | D | This composite is only used when trading partners have agreed to use mutually defined code values. |
| 4441 | Free text value code | M an..17 | M | |
| 1131 | Code list identification code | C an..17 | O | |
| 3055 | Code list responsible agency code | C an..3 | D | 9 = GS1 91 = Assigned by supplier or supplier's agent 92 = Assigned by buyer or buyer's agent |
| C108 | TEXT LITERAL | C | D | This composite is only used if coded text can not be used. |
| 4440 | Free text value | M an..512 | M | |
| 4440 | Free text value | C an..512 | O | |
| 4440 | Free text value | C an..512 | O | |
| 4440 | Free text value | C an..512 | O | |
| 4440 | Free text value | C an..512 | O | |
| 3453 | Language name code | C an..3 | D | ISO 639 two alpha code This data element is only used when non coded free text has been provided in data element C108. |
| 4447 | Free text format code | C an..3 | N | |
| Segment Notes: | | | | |
| <p>This segment is used to provide any free text information related to the status detailed in the STS segment. Use of this segment in free form is not recommended since it may inhibit automatic processing of the Transport Status. Coded references to standard texts is an available functionality which enables automatic processing and reduces transmission overheads. Standard texts should be mutually defined between trading partners and can be used to cover legal or other requirements.</p> <p>Example: FTX+HAN++012::91' Code "012" is agreed to express = Please ensure correct storage conditions for the consignment. FTX+TRA+++NEW DELIVERY ATTEMPT TOMORROW'</p> | | | | |

5. Segments Layout

Segment number: 14

| | | |
|------------|-----|---------------------------------------|
| SG4 | - C | 99999 - CNI-SG5 |
| SG5 | - M | 99 - STS-RFF-DTM-FTX-SG6-LOC-SG8-SG12 |
| SG6 | - C | 9 - NAD |
| NAD | - M | 1 - Name and address |

Function:
To specify the name/address and their related function, either by C082 only and/or unstructured by C058 or structured by C080 thru 3207.

| | EDIFACT | GS1 | * | Description |
|--|----------|----------|---|--|
| 3035 Party function code qualifier | M an..3 | M | | CA = Carrier CN = Consignee CZ = Consignor DP = Delivery party FW = Freight forwarder PW = Despatch party |
| C082 PARTY IDENTIFICATION DETAILS | C | A | | |
| 3039 Party identifier | M an..35 | M | | GLN - Format n13 For the identification of parties it is recommended to use GLN - Format n13. |
| 1131 Code list identification code | C an..17 | N | | |
| 3055 Code list responsible agency code | C an..3 | R | * | 9 = GS1 |
| C058 NAME AND ADDRESS | C | O | | This composite may only be used to fulfill the requirements of directive 2003/58/EC, article 4. |
| 3124 Name and address description | M an..35 | M | | |
| 3124 Name and address description | C an..35 | O | | |
| 3124 Name and address description | C an..35 | O | | |
| 3124 Name and address description | C an..35 | O | | |
| 3124 Name and address description | C an..35 | O | | |
| C080 PARTY NAME | C | D | | |
| 3036 Party name | M an..35 | M | | Party Name, clear text |
| 3036 Party name | C an..35 | O | | |
| 3036 Party name | C an..35 | O | | |
| 3036 Party name | C an..35 | O | | |
| 3036 Party name | C an..35 | O | | |
| 3045 Party name format code | C an..3 | O | | |
| C059 STREET | C | D | | |
| 3042 Street and number or post office box identifier | M an..35 | M | | Building Name/Number and Street |
| 3042 Street and number or post office box identifier | C an..35 | O | | Name and/or P.O. Box |
| 3042 Street and number or post office box identifier | C an..35 | O | | |
| 3042 Street and number or post office box identifier | C an..35 | O | | |
| 3164 City name | C an..35 | D | | City/Town, clear text |

5. Segments Layout

Segment number: 14

| | | EDIFACT | GS1 | * | Description |
|------|-----------------------------------|----------|-----|---|---------------------------|
| C819 | COUNTRY SUB-ENTITY DETAILS | C | D | | |
| 3229 | Country sub-entity name code | C an..9 | O | | |
| 1131 | Code list identification code | C an..17 | O | | |
| 3055 | Code list responsible agency code | C an..3 | O | | |
| 3228 | Country sub-entity name | C an..70 | O | | County/State, clear text. |
| 3251 | Postal identification code | C an..17 | D | | Postal Code |
| 3207 | Country name code | C an..3 | D | | ISO 3166 two alpha code |

Segment Notes:

This segment is used to specify parties related to the status provided in the STS segment.

Example:

NAD+PW+5411234512385::9'

NAD+DP+5412345122258::9'

Dependency Notes:

The following composites and data elements are only used when a coded name and address can not be used.

The affected composites and data elements are as follows:

C080 - C059 - 3164 - C819 - 3251 - 3207

5. Segments Layout

Segment number: 15

| SG4 | - C | 99999 - CNI-SG5 | | | |
|--|--|---------------------------------------|----------|-------------|---|
| SG5 | - M | 99 - STS-RFF-DTM-FTX-SG6-LOC-SG8-SG12 | | | |
| LOC | - C | 1 - Place/location identification | | | |
| Function: | | | | | |
| To identify a place or a location and/or related locations. | | | | | |
| | EDIFACT | GS1 | * | Description | |
| 3227 | Location function code qualifier | M an..3 | M | * | 300 = Location of status |
| C517 | LOCATION IDENTIFICATION | C | A | | |
| 3225 | Location name code | C an..25 | A | | GLN - Format n13 |
| 1131 | Code list identification code | C an..17 | O | | |
| 3055 | Code list responsible agency code | C an..3 | D | | 9 = GS1 DE 3055 must be used if DE 3225 is used and does not contain an UN/LOCODE. |
| 3224 | Location name | C an..256 | O | | |
| C519 | RELATED LOCATION ONE IDENTIFICATION | C | N | | |
| 3223 | First related location name code | C an..25 | | | |
| 1131 | Code list identification code | C an..17 | | | |
| 3055 | Code list responsible agency code | C an..3 | | | |
| 3222 | First related location name | C an..70 | | | |
| C553 | RELATED LOCATION TWO IDENTIFICATION | C | N | | |
| 3233 | Second related location name code | C an..25 | | | |
| 1131 | Code list identification code | C an..17 | | | |
| 3055 | Code list responsible agency code | C an..3 | | | |
| 3232 | Second related location name | C an..70 | | | |
| 5479 | Relation code | C an..3 | N | | |
| Segment Notes: | | | | | |
| This segment is used to indicate a location relevant to the status provided in the STS segment. It is recommended to use Global Location Numbers GLN - Format n13 - for the identification of the location. | | | | | |
| Example: LOC+300+5412345678908::9' | | | | | |

5. Segments Layout

Segment number: 16

| SG4 | - C | 99999 - CNI-SG5 | | | |
|--|--|---------------------------------------|----------|-------------|--|
| SG5 | - M | 99 - STS-RFF-DTM-FTX-SG6-LOC-SG8-SG12 | | | |
| SG8 | - C | 99 - TDT-SG9 | | | |
| TDT | - M | 1 - Details of transport | | | |
| Function: | | | | | |
| To specify the transport details such as mode of transport, means of transport, its conveyance reference number and the identification of the means of transport. The segment may be pointed to by the TPL segment. | | | | | |
| | EDIFACT | GS1 | * | Description | |
| 8051 | Transport stage code qualifier | M an..3 | M | * | 20 = Main-carriage transport |
| 8028 | Means of transport journey identifier | C an..17 | O | | Reference number covering the transport |
| C220 | MODE OF TRANSPORT | C | A | | |
| 8067 | Transport mode name code | C an..3 | R | | |
| 8066 | Transport mode name | C an..17 | N | | |
| C228 | TRANSPORT MEANS | C | O | | |
| 8179 | Transport means description code | C an..8 | D | | 31 = Truck Data Element 8179 is only used when the type of transport must be specifically identified, that is, a generic description such as road transport is unsuitable. |
| 8178 | Transport means description | C an..17 | N | | |
| C040 | CARRIER | C | O | | |
| 3127 | Carrier identifier | C an..17 | R | | Global Location Number GLN - Format n13 |
| 1131 | Code list identification code | C an..17 | N | | |
| 3055 | Code list responsible agency code | C an..3 | R | * | 9 = GS1 |
| 3128 | Carrier name | C an..35 | N | | |
| 8101 | Transit direction indicator code | C an..3 | N | | |
| C401 | EXCESS TRANSPORTATION INFORMATION | C | N | | |
| 8457 | Excess transportation reason code | M an..3 | | | |
| 8459 | Excess transportation responsibility code | M an..3 | | | |
| 7130 | Customer shipment authorisation identifier | C an..17 | | | |
| C222 | TRANSPORT IDENTIFICATION | C | O | | |
| 8213 | Transport means identification name identifier | C an..9 | N | | |
| 1131 | Code list identification code | C an..17 | N | | |
| 3055 | Code list responsible agency code | C an..3 | N | | |
| 8212 | Transport means identification name | C an..35 | R | | Vehicle license plate |

5. Segments Layout

Segment number: 16

| | EDIFACT | GS1 | * | Description |
|---|---------|-----|---|-------------------------|
| 8453 Transport means nationality code | C an..3 | O | | ISO 3166 two alpha code |
| 8281 Transport means ownership indicator code | C an..3 | N | | |

Segment Notes:

This segment is used to specify transport details for the current consignment.

Example:

TDT+20+KTO-97+30+31++++:::ABX712'

The transport of consignment will be done with the truck with license plate 'ABX712'.

5. Segments Layout

Segment number: 17

| | | |
|------------|-----|---------------------------------------|
| SG4 | - C | 99999 - CNI-SG5 |
| SG5 | - M | 99 - STS-RFF-DTM-FTX-SG6-LOC-SG8-SG12 |
| SG8 | - C | 99 - TDT-SG9 |
| SG9 | - C | 9 - LOC-DTM |
| LOC | - M | 1 - Place/location identification |

Function:
To identify a place or a location and/or related locations.

| | EDIFACT | GS1 | * | Description |
|------|--|-----------|----------|---|
| 3227 | Location function code qualifier | M an..3 | M | 9 = Place/port of loading |
| C517 | LOCATION IDENTIFICATION | C | A | |
| 3225 | Location name code | C an..25 | A | GLN - Format n13 |
| 1131 | Code list identification code | C an..17 | O | |
| 3055 | Code list responsible agency code | C an..3 | D | 9 = GS1 DE 3055 must be used if DE 3225 is used and does not contain an UN/LOCODE. |
| 3224 | Location name | C an..256 | O | |
| C519 | RELATED LOCATION ONE IDENTIFICATION | C | N | |
| 3223 | First related location name code | C an..25 | | |
| 1131 | Code list identification code | C an..17 | | |
| 3055 | Code list responsible agency code | C an..3 | | |
| 3222 | First related location name | C an..70 | | |
| C553 | RELATED LOCATION TWO IDENTIFICATION | C | N | |
| 3233 | Second related location name code | C an..25 | | |
| 1131 | Code list identification code | C an..17 | | |
| 3055 | Code list responsible agency code | C an..3 | | |
| 3232 | Second related location name | C an..70 | | |
| 5479 | Relation code | C an..3 | N | |

Segment Notes:
This segment is used to identify any locations related to the transport details specified in the previous TDT segment.

Example:
LOC+9+5412345678908::9'

5. Segments Layout

Segment number: 18

| | | |
|------------|-----|---------------------------------------|
| SG4 | - C | 99999 - CNI-SG5 |
| SG5 | - M | 99 - STS-RFF-DTM-FTX-SG6-LOC-SG8-SG12 |
| SG8 | - C | 99 - TDT-SG9 |
| SG9 | - C | 9 - LOC-DTM |
| DTM | - C | 9 - Date/time/period |

Function:

To specify date, and/or time, or period.

| | | EDIFACT | GS1 | * | Description |
|------|--|----------|-----|---|---|
| C507 | DATE/TIME/PERIOD | M | M | | |
| 2005 | Date or time or period function code qualifier | M an..3 | M | * | 132 = Arrival date/time, estimated 133 = Departure date/time, estimated 190 = Transshipment date/time |
| 2380 | Date or time or period value | C an..35 | R | | |
| 2379 | Date or time or period format code | C an..3 | R | | 102 = CCYMMDD 203 = CCYMMDDHHMM 719 = CCYMMDDHHMM- CCYMMDDHHMM |

Segment Notes:

This segment is used to specify any dates relating to the transport specified in the previous TDT segment.

Example:

DTM+132:200212151000:203'

Estimated arrival date/time of the transport means is 10:00am on the 15th of December 2002.

5. Segments Layout

Segment number: 19

| SG4 | - C | 99999 - CNI-SG5 | | |
|-------------------------------------|------------------------------------|---------------------------------------|---|--|
| SG5 | - M | 99 - STS-RFF-DTM-FTX-SG6-LOC-SG8-SG12 | | |
| SG12 | - C | 99 - GID-SG13-SG14-SG15 | | |
| GID | - M | 1 - Goods item details | | |
| Function: | | | | |
| To indicate totals of a goods item. | | | | |
| | EDIFACT | GS1 | * | Description |
| 1496 | Goods item number | C n..5 | R | Application number identifying items within the current consignment. |
| C213 | NUMBER AND TYPE OF PACKAGES | C | R | |
| 7224 | Package quantity | C n..8 | R | |
| 7065 | Package type description code | C an..17 | O | 09 = Returnable pallet (GS1 Temporary Code) 201 = Pallet ISO 1 - 1/1 EURO Pallet (GS1 Temporary Code) |
| 1131 | Code list identification code | C an..17 | N | |
| 3055 | Code list responsible agency code | C an..3 | D | * 9 = GS1 This data element is only used with the code value '9' if the type of packages identified in data element 7065 is and GS1 code. |
| 7064 | Type of packages | C an..35 | N | |
| 7233 | Packaging related description code | C an..3 | N | |
| C213 | NUMBER AND TYPE OF PACKAGES | C | N | |
| 7224 | Package quantity | C n..8 | | |
| 7065 | Package type description code | C an..17 | | |
| 1131 | Code list identification code | C an..17 | | |
| 3055 | Code list responsible agency code | C an..3 | | |
| 7064 | Type of packages | C an..35 | | |
| 7233 | Packaging related description code | C an..3 | | |
| C213 | NUMBER AND TYPE OF PACKAGES | C | N | |
| 7224 | Package quantity | C n..8 | | |
| 7065 | Package type description code | C an..17 | | |
| 1131 | Code list identification code | C an..17 | | |
| 3055 | Code list responsible agency code | C an..3 | | |
| 7064 | Type of packages | C an..35 | | |
| 7233 | Packaging related description code | C an..3 | | |
| C213 | NUMBER AND TYPE OF PACKAGES | C | N | |

5. Segments Layout

Segment number: 19

| | EDIFACT | GS1 | * | Description |
|---|----------|-----|---|-------------|
| 7224 Package quantity | C n..8 | | | |
| 7065 Package type description code | C an..17 | | | |
| 1131 Code list identification code | C an..17 | | | |
| 3055 Code list responsible agency code | C an..3 | | | |
| 7064 Type of packages | C an..35 | | | |
| 7233 Packaging related description code | C an..3 | | | |
| C213 NUMBER AND TYPE OF PACKAGES | C | N | | |
| 7224 Package quantity | C n..8 | | | |
| 7065 Package type description code | C an..17 | | | |
| 1131 Code list identification code | C an..17 | | | |
| 3055 Code list responsible agency code | C an..3 | | | |
| 7064 Type of packages | C an..35 | | | |
| 7233 Packaging related description code | C an..3 | | | |

Segment Notes:

This segment is used to identify goods items for which status information is being provided in the STS segment.

Example:

GID+1+1:09::9'

Goods item 1 is made up of 1 returnable pallet.

5. Segments Layout

Segment number: 20

| | | |
|-------------|-----|---------------------------------------|
| SG4 | - C | 99999 - CNI-SG5 |
| SG5 | - M | 99 - STS-RFF-DTM-FTX-SG6-LOC-SG8-SG12 |
| SG12 | - C | 99 - GID-SG13-SG14-SG15 |
| SG13 | - C | 99 - MEA |
| MEA | - M | 1 - Measurements |

Function:

To specify physical measurements, including dimension tolerances, weights and counts.

| | | EDIFACT | GS1 | * | Description |
|------|---------------------------------------|----------|----------|---|--|
| 6311 | Measurement purpose code qualifier | M an..3 | M | | PD = Physical dimensions (product ordered) |
| C502 | MEASUREMENT DETAILS | C | A | | |
| 6313 | Measured attribute code | C an..3 | A | | AAC = Total net weight AAD = Total gross weight |
| 6321 | Measurement significance code | C an..3 | N | | |
| 6155 | Non-discrete measurement name code | C an..17 | N | | |
| 6154 | Non-discrete measurement name | C an..70 | N | | |
| C174 | VALUE/RANGE | C | R | | |
| 6411 | Measurement unit code | M an..3 | M | | |
| 6314 | Measurement value | C an..18 | O | | |
| 6162 | Range minimum value | C n..18 | O | | |
| 6152 | Range maximum value | C n..18 | N | | |
| 6432 | Significant digits quantity | C n..2 | N | | |
| 7383 | Surface or layer code | C an..3 | N | | |

Segment Notes:

This segment is used to specify the total net and gross weight of the goods item identified in GID.

Example:

MEA+PD+AAB+GRM:1250'

5. Segments Layout

Segment number: 21

| | | |
|-------------|-----|---------------------------------------|
| SG4 | - C | 99999 - CNI-SG5 |
| SG5 | - M | 99 - STS-RFF-DTM-FTX-SG6-LOC-SG8-SG12 |
| SG12 | - C | 99 - GID-SG13-SG14-SG15 |
| SG14 | - C | 99 - DIM |
| DIM | - M | 1 - Dimensions |

Function:

To specify dimensions.

| | EDIFACT | GS1 | * | Description |
|------------------------------------|---------|----------|---|---|
| 6145 Dimension type code qualifier | M an..3 | M | * | This qualifier determines the dimension values to be applied either to one single despatch unit of the goods item or to a number of despatch units of the goods item. 1 = Gross dimensions 10E = Unit gross dimensions (GS1 Temporary Code) |
| C211 DIMENSIONS | M | M | | |
| 6411 Measurement unit code | M an..3 | M | | |
| 6168 Length dimension value | C n..15 | O | | |
| 6140 Width dimension value | C n..15 | O | | |
| 6008 Height dimension value | C n..15 | O | | |

Segment Notes:

This segment is used to indicate the dimensions of the goods item identified in the GID segment.

All dimensions given in the DIM segments relate to the highest level packaging (the despatch units) identified in the GID segment.

When Unit Gross Dimensions are provided in this segment the dimension values provided relate to the total gross dimensions of one single despatch unit in the goods item.

When Gross Dimensions are provided the dimension values relate to the total gross weight of a number of despatch units in the goods item.

Example:

DIM+1+MTR:4:2:2'

5. Segments Layout

Segment number: 22

| | | |
|-------------|-----|---------------------------------------|
| SG4 | - C | 99999 - CNI-SG5 |
| SG5 | - M | 99 - STS-RFF-DTM-FTX-SG6-LOC-SG8-SG12 |
| SG12 | - C | 99 - GID-SG13-SG14-SG15 |
| SG15 | - C | 99 - PCI-GIN |
| PCI | - M | 1 - Package identification |

Function:
 To specify markings and labels on individual packages or physical units.

| | | EDIFACT | GS1 | * | Description |
|------|--|----------|-----|---|--|
| 4233 | Marking instructions code | C an..3 | R | | 39 = Marked with Serial Shipping Container Code (SSCC) |
| C210 | MARKS & LABELS | C | O | | |
| 7102 | Shipping marks description | M an..35 | M | | |
| 7102 | Shipping marks description | C an..35 | O | | |
| 7102 | Shipping marks description | C an..35 | O | | |
| 7102 | Shipping marks description | C an..35 | O | | |
| 7102 | Shipping marks description | C an..35 | O | | |
| 7102 | Shipping marks description | C an..35 | O | | |
| 7102 | Shipping marks description | C an..35 | O | | |
| 7102 | Shipping marks description | C an..35 | O | | |
| 7102 | Shipping marks description | C an..35 | O | | |
| 7102 | Shipping marks description | C an..35 | O | | |
| 8275 | Container or package contents indicator code | C an..3 | N | | |
| C827 | TYPE OF MARKING | C | N | | |
| 7511 | Marking type code | M an..3 | | | |
| 1131 | Code list identification code | C an..17 | | | |
| 3055 | Code list responsible agency code | C an..3 | | | |

Segment Notes:
 This segment is used to specify markings and labels for the line item identified in the GID segment.

Example:
 PCI+39'

5. Segments Layout

Segment number: 23

| | | |
|-------------|-----|---------------------------------------|
| SG4 | - C | 99999 - CNI-SG5 |
| SG5 | - M | 99 - STS-RFF-DTM-FTX-SG6-LOC-SG8-SG12 |
| SG12 | - C | 99 - GID-SG13-SG14-SG15 |
| SG15 | - C | 99 - PCI-GIN |
| GIN | - C | 9 - Goods identity number |

Function:

To give specific identification numbers, either as single numbers or ranges.

| | | EDIFACT | GS1 | * | Description |
|------|---|----------|----------|---|---|
| 7405 | Object identification code qualifier | M an..3 | M | * | AW = Serial shipping container code BJ = Serial shipping container code In EANCOM it is required to use the Serial Shipping Container Code (SSCC's) for unique identification of individual transport packages. |
| C208 | IDENTITY NUMBER RANGE | M | M | | |
| 7402 | Object identifier | M an..35 | M | | |
| 7402 | Object identifier | C an..35 | O | | |
| C208 | IDENTITY NUMBER RANGE | C | O | | |
| 7402 | Object identifier | M an..35 | M | | |
| 7402 | Object identifier | C an..35 | O | | |
| C208 | IDENTITY NUMBER RANGE | C | O | | |
| 7402 | Object identifier | M an..35 | M | | |
| 7402 | Object identifier | C an..35 | O | | |
| C208 | IDENTITY NUMBER RANGE | C | O | | |
| 7402 | Object identifier | M an..35 | M | | |
| 7402 | Object identifier | C an..35 | O | | |
| C208 | IDENTITY NUMBER RANGE | C | O | | |
| 7402 | Object identifier | M an..35 | M | | |
| 7402 | Object identifier | C an..35 | O | | |

Segment Notes:

This segment is used to provide the Serial Shipping Container Code marked on the packaging of the current goods item.

Example:

GIN+AW+354123450000000014'

5. Segments Layout

Segment number: 24

| UNT - M 1 - Message trailer | | | | | |
|--|---------------------------------|----------|----------|---|---|
| Function: To end and check the completeness of a message. | | | | | |
| Notes: 1. 0062, the value shall be identical to the value in 0062 in the corresponding UNH segment. | | | | | |
| | | EDIFACT | GS1 | * | Description |
| 0074 | Number of segments in a message | M n..10 | M | | The total number of segments contained in the message is detailed here. |
| 0062 | Message reference number | M an..14 | M | | The message reference numbered detailed here should equal the one specified in the UNH segment. |
| Segment Notes: This UNT segment is a mandatory UN/EDIFACT segment. It must always be the last segment in the message. | | | | | |
| Example: UNT+24+ME000001' | | | | | |

5. Segments Layout

Segment number: 25

| UNZ - M 1 - Interchange trailer | | | | | |
|---|-------------------------------|----------|----------|---|--|
| Function: To end and check the completeness of an interchange. | | | | | |
| Notes: 1. 0020, the value shall be identical to the value in 0020 in the corresponding UNB segment. | | | | | |
| | | EDIFACT | GS1 | * | Description |
| 0036 | Interchange control count | M n..6 | M | | Number of messages or functional groups within an interchange. |
| 0020 | Interchange control reference | M an..14 | M | | Identical to DE 0020 in UNB segment. |
| Segment Notes: This segment is used to provide the trailer of an interchange. DE 0036: If functional groups are used, this is the number of functional groups within the interchange. If functional groups are not used, this is the number of messages within the interchange. UNZ+5+1234555' | | | | | |

6. Examples

The following is an example of a transport status message between a freight forwarder identified by GLN 5422331123459 and a consignor identified by GLN 5412345123453. The message is dated the 4th of February 2002 and has the message reference number 95-455.

The message provides status information on four consignments identified by the consignment numbers 4215A, 5122C, 5145E, and 7655S.

First consignment number 4215A is reported as being delivered to the delivery party identified by GLN 5411111123451 at 14:50 on the 1st of February 2002. The delivery note number which covers the delivery is 5/2334.

Second consignment number 5122C is reported as being en route. The next report on the status is scheduled for the 7th of February 2002.

Third consignment number 5145E is reported as being refused by the customs and excise at London Heathrow Airport because of export restrictions. The refusal took place on the 15th of January 2002.

Fourth consignment number 7655S is reported as being partially lost and partially delivered. It contains 3 goods items each of which is being reported individually. Goods item 1, which was packed in a carton identified by the EAN.UCC SSCC 35410738000001051, and goods 3, which was packed on a returnable pallet identified by the EAN.UCC SSCC 354123451234567892, are reported as being delivered on the 28th of January 2002. Goods item 2, which was packed in a carton and marked with the EAN.UCC SSCC 35410738000001068 is reported as being lost. The date on which it was discovered as being lost is the 28th of January 2002.

| | |
|---|--|
| UNH+ME000021+IFTSTA:D:01A:UN:EAN004' | Message header |
| BGM+44+95-455+9' | Transport status number 95-455 |
| DTM+137:20020204:102' | Message date/time 4th February 2002 |
| NAD+FW+5422331123459::9' | Freight forwarder identified with GLN 5422331123459 |
| NAD+CZ+5412345123453::9' | Consignor identified with GLN 5412345123453 |
| CNI+1+4215A' | First consignment number 4215A |
| STS+1+21' | Status of the consignment: 'delivered' |
| RFF+DQ:5/2334' | Reference is a delivery note number '5/2334' |
| DTM+334:200202011450:203' | Date/time of the status change 1st February 2002 at 14:50 |
| NAD+DP+5411111123451::9' | Delivery party identified with GLN 5411111123451 |
| CNI+2+5122C' | Second consignment number 5122C |
| STS+1+31' | Status of the consignment: 'Goods on their way' |
| DTM+40E:20020207:102' | Date/time of the next status 7th February 2002 |
| CNI+3+5145E' | Third consignment number 5145E |
| STS+1+17+39' | The consignment was customs refused and no recipient contact information |
| DTM+334:20020115:102' | The refusal took place 15th January 2002 |
| LOC+16E+:::H.MCUSTOMS AND EXCISE LONDON HEATHROW AIRPORT' | Identify customs in Heathrow airport as the location of the status |
| CNI+4+7655S' | Fourth consignment number 7655S |

6. Examples

| | |
|----------------------------|--|
| STS+1+49' | The following goods item are lost |
| DTM+334:20020128:102' | Date/time reported lost 28th January 2002 |
| GID+1+1:CT' | One carton box, first goods item |
| PCI+33E' | EAN.UCC SSCC |
| GIN+BJ+35410738000001068' | 35410738000001068 |
| STS+1+21' | The following goods items have been delivered |
| DTM+334:20020128:102' | Delivered 28th January 2002 |
| GID+2+1:CT' | One cardboard box, second goods item |
| PCI+33E' | Box marked with EAN.UCC SSCC |
| GIN+BJ+35410738000001051' | EAN.UCC SSCC 35410738000001051 |
| STS+1+21' | Consignment delivered |
| DTM+334:20020128:102' | Delivered 28th January 2002 |
| GID+3+1:09::9' | One returnable pallet, third goods item |
| PCI+33E' | Pallet marked with EAN.UCC SSCC |
| GIN+BJ+354123451234567892' | EAN.UCC SSCC 354123451234567892 |
| UNT+34+ME000021' | Total number of segments in the message equals 34 |

Note:

The EDI interchange will include the UNB..UNZ segments and, if applicable, the UNG..UNE segments (see part I section 5.7).